

SECOND FLOOR PLAN

0 2 4 6 FT.

REAR WALL AT SECOND FLOOR MAY BE CONSTRUCTED AT END SET OF RAFTERS THEREBY INCREASING LENGTH OF BEDROOM. IF THIS IS DONE SUBSTITUTE A DOUBLE HUNG WINDOW FOR DOOR.

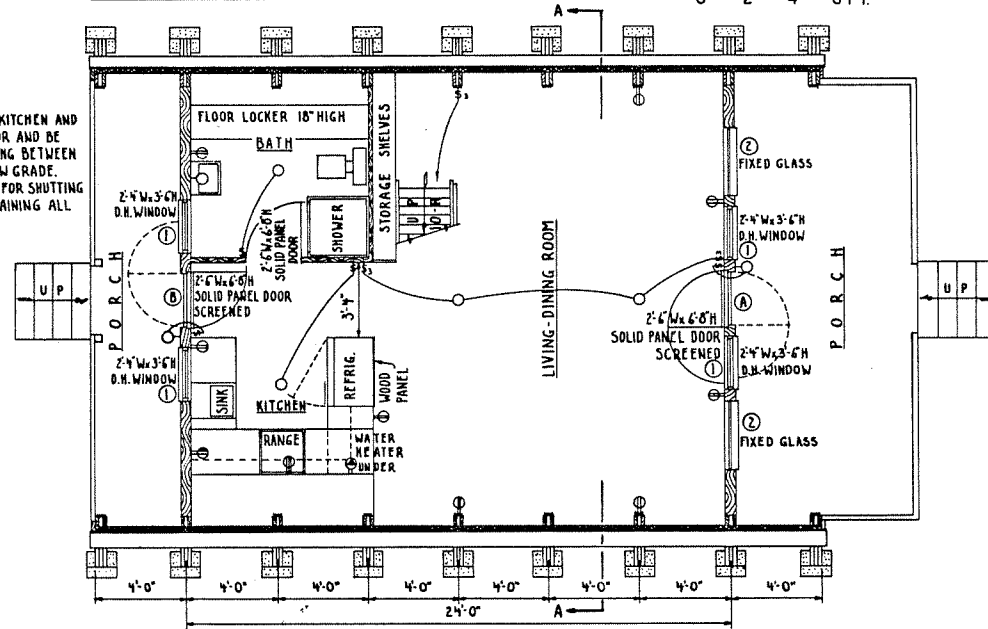

FIRST FLOOR PLAN

0 2 4 6 FT.

WATER AND SOIL LINES FOR KITCHEN AND BATH TO EXTEND THRU FLOOR AND BE INSULATED AGAINST FREEZING BETWEEN FLOOR AND FROST LINE BELOW GRADE. PROVISION SHOULD BE MADE FOR SHUTTING OFF WATER TO CABIN AND DRAINING ALL LINES.

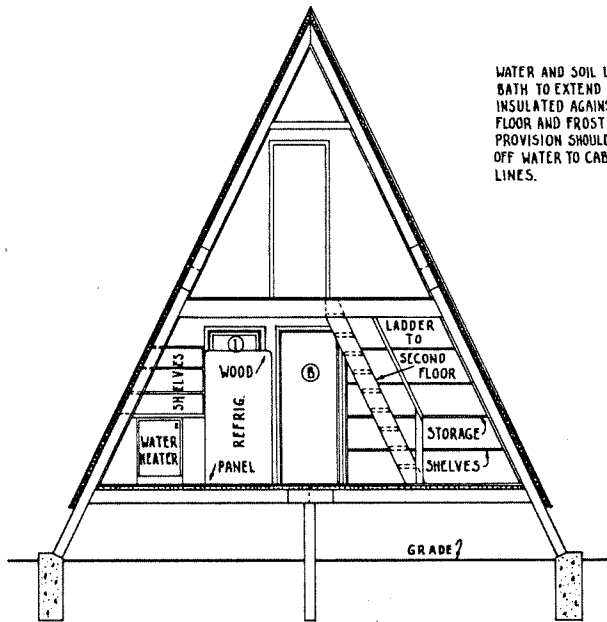

SECTION A-A

0 2 4 6 FT.

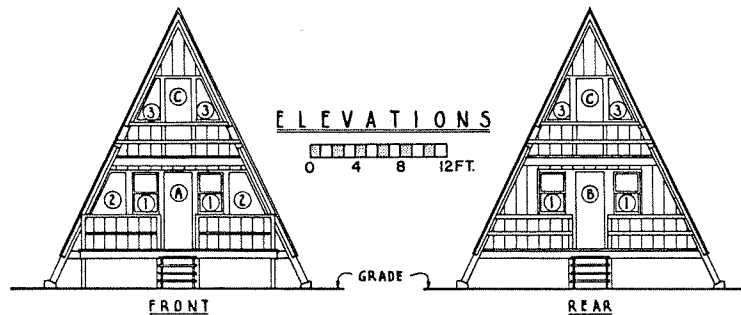

ELEVATIONS

0 4 8 12 FT.

COOPERATIVE EXTENSION WORK IN
 AGRICULTURE AND HOME ECONOMICS
 DEPARTMENT OF AGRICULTURAL ENGINEERING
 UNIVERSITY OF MARYLAND
 AND
 UNITED STATES DEPARTMENT OF AGRICULTURE COOPERATING

24'-0" A FRAME CABIN

USDA 1963 EX. 5964 SHEET 1 OF 3

NOTE -
DESIGNED FOR BENDING FIBER STRESS
OF 1200 psi IN TIMBERS.
WIND LOADS OF 65 MPH WINDS.

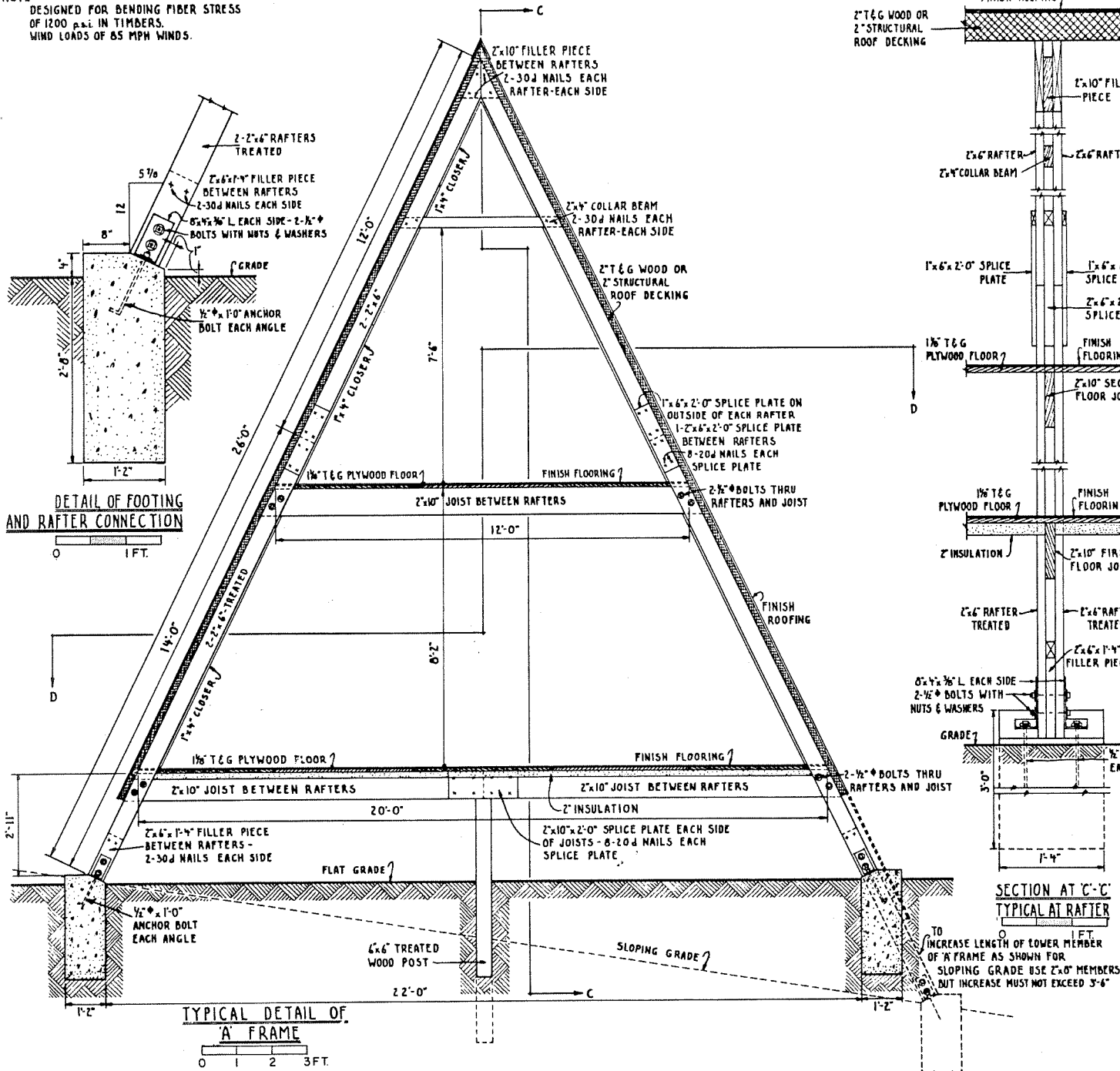

DETAIL OF FOOTING AND RAFTER CONNECTION

0 1 FT.

TYPICAL DETAIL OF 'A' FRAME

0 1 2 3 FT.

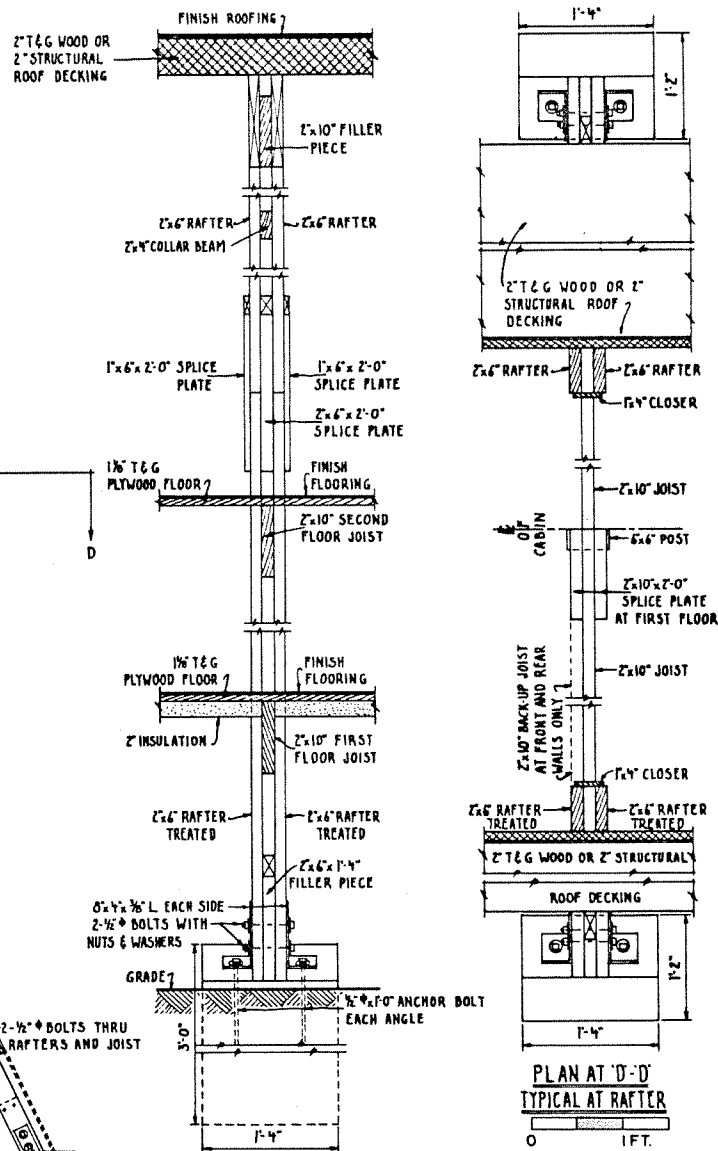

SECTION AT 'C-C' TYPICAL AT RAFTER

COOPERATIVE EXTENSION WORK IN
AGRICULTURE AND HOME ECONOMICS
DEPARTMENT OF AGRICULTURAL ENGINEERING
UNIVERSITY OF MARYLAND
AND
UNITED STATES DEPARTMENT OF AGRICULTURE COOPERATING

24'-0" A FRAME CABIN

USDA 1963 EX-5964 SHEET 2 OF 3

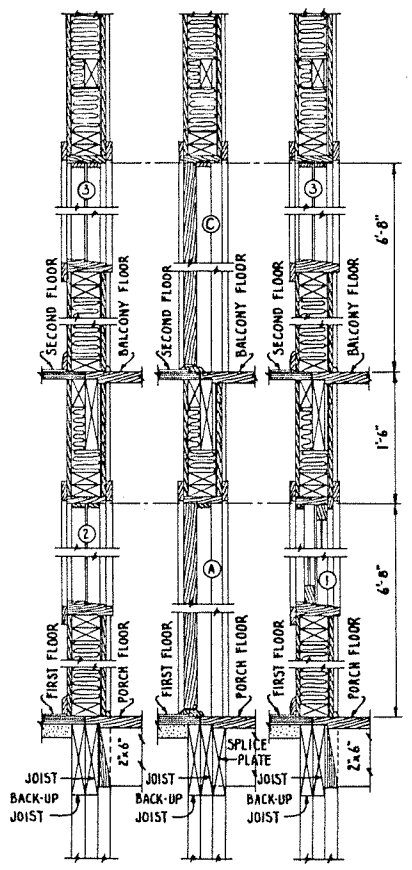
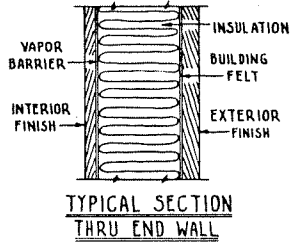
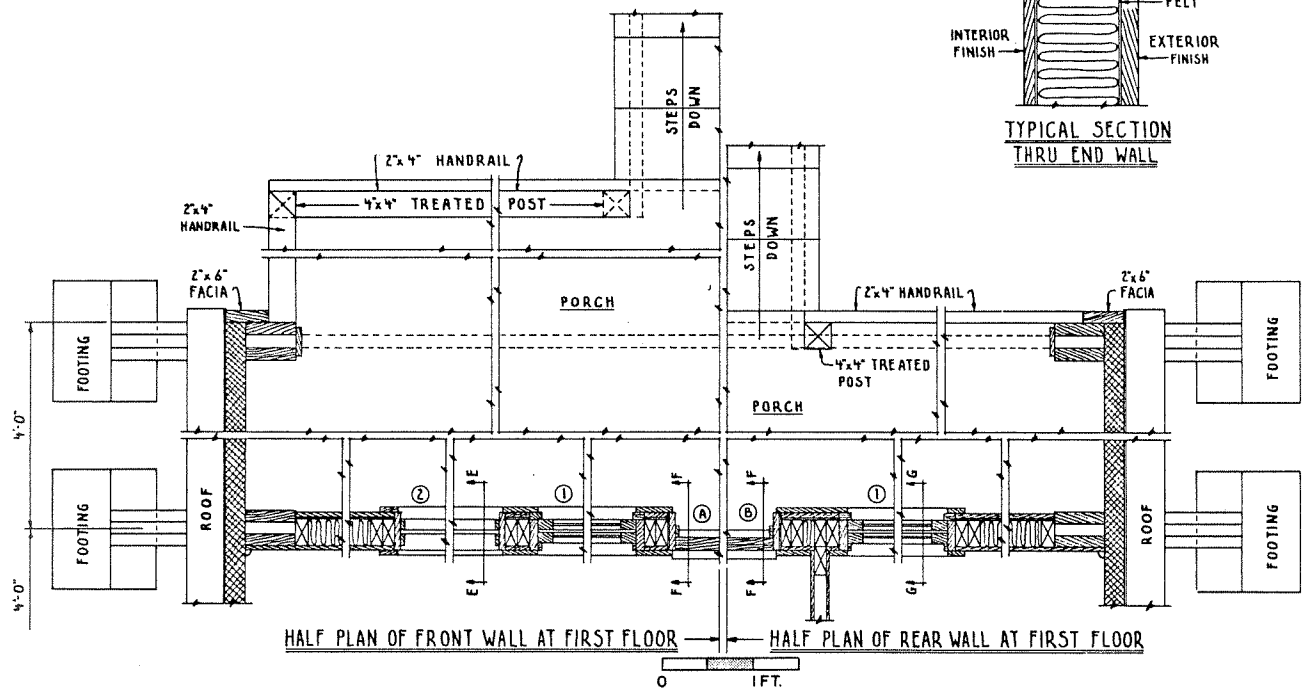

SECTION E-E SECTION F-F SECTION G-G
 0 1 FT.
 NOTE - PORCH CONSTRUCTION - 2" PLANKING ON 2x6 FRAMING - 2'-0" O.C.

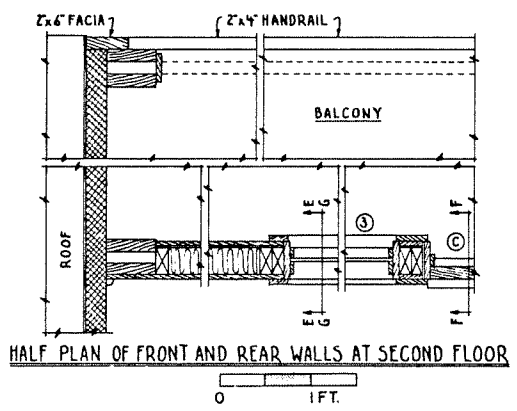

COOPERATIVE EXTENSION WORK IN
 AGRICULTURE AND HOME ECONOMICS
 DEPARTMENT OF AGRICULTURAL ENGINEERING
 UNIVERSITY OF MARYLAND
 AND
 UNITED STATES DEPARTMENT OF AGRICULTURE COOPERATING

24'-0" A FRAME CABIN

USDA 1963 EX-5964 SHEET 3 OF 3